



FITTING INSTRUCTIONS FOR LP0335BK LICENCE PLATE BRACKET
TRIUMPH TIGER SPORT 660 2022-



This kit contains the items pictured and labelled over page.

Some parts may be shown for clarity of instructions only.

Do not proceed until you are sure all parts are present.

Please read all instructions before proceeding.

IF IN ANY DOUBT WHEN FITTING OUR PRODUCTS, CONSULT ONE OF OUR DEALERS
OR HAVE FITTED BY A QUALIFIED TECHNICIAN.

Please note that the way the kit is packed does not necessarily represent the way of mounting to the bike.

In the event of rubber washers being used to hold components onto bolts, these rubber washers can be thrown away.

DIGITAL COPIES OF THESE INSTRUCTIONS ARE AVAILABLE FROM

WWW.RG-RACING.COM

R&G

Unit 1, Shelley's Lane, East Worldham, Alton, Hampshire, GU34 3AQ

Tel: +44 (0)1420 89007 Fax: +44 (0)1420 87301 www.rg-racing.com Email: info@rg-racing.com



<u>TOOLS REQUIRED</u>	<u>GENERAL TORQUE SETTINGS</u>
<ul style="list-style-type: none"> • Set metric allen keys. • Set of metric sockets and ratchet. • Small flat head screwdriver. • Small amount of super glue. • Threadlocker 	<p>M4 BOLT = 8Nm</p> <p>M5 BOLT = 12Nm</p> <p>M6 BOLT = 15Nm</p> <p>M8 BOLT = 20Nm</p> <p>M10 BOLT = 40Nm</p> <p>M12 BOLT = 40Nm</p>

LEGEND

ITEM No.	DESCRIPTION	QTY
ITEM 1	TB0335 PART 1 (MAIN LHS STEEL BRACKET)	1
ITEM 2	TB0335 PART 2 (MAIN RHS STEEL BRACKET)	1
ITEM 3	TB0335 PART 3 (LICENSE PLATE ALUMINIUM BRACKET)	1
ITEM 4	TB0335 PART 4 (STEEL MOUNTING PLATE WITH COVER)	1
ITEM 5	TB0335 PART 5 (WIRING COVER PLATE)	1
ITEM 6	LA0002 (LICENSE PLATE ILLUMINATOR)	1
ITEM 7	CON0014	1
ITEM 8	M5 x 0.80 x 15mm CSK BOLT	5
ITEM 9	M5 x 0.80 x 8mm CSK BOLT	1
ITEM 10	M5 x 10mm OD WASHER	5
ITEM 11	M5 x 0.80 NYLOC NUT	5
ITEM 12	M6 x 1.00 16mm BUTTON HEAD BOLT	2
ITEM 13	M6 x 12mm OD WASHER	7
ITEM 14	M6 x 1.00 NYLOC NUT	4
ITEM 15	M6 x 1.00 x 25mm BUTTON HEAD BOLT	3
ITEM 16	M6 x 19mm OD WASHER	2
ITEM 17	M6 x 1.00 x 6mm BUTTON HEAD BOLT	2
ITEM 18	IWC0002 (INDICATOR WIRING COVER)	2
ITEM 19	666-896 (200mm LENGTH OF HEAT-SHRINK)	3
ITEM 20	CT75 (2.5mm WIDE x 75mm LONG CABLE TIES)	2
ITEM 21	CLIP1 (SELF ADHESIVE CABLE CLIPS)	3
ITEM 22	REFL3 (REFLECTOR)	1

R&G

Unit 1, Shelley's Lane, East Worldham, Alton, Hampshire, GU34 3AQ

Tel: +44 (0)1420 89007 Fax: +44 (0)1420 87301 www.rg-racing.com Email: info@rg-racing.com



ASSEMBLY DIAGRAM 1

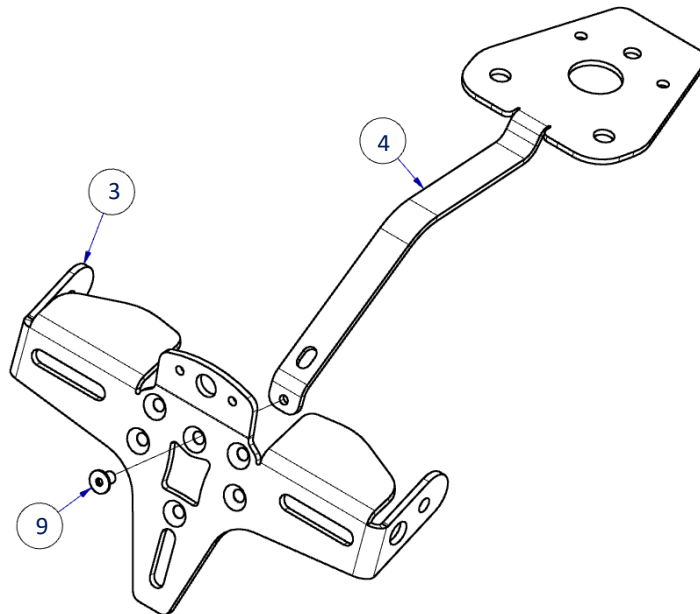

ASSEMBLY DIAGRAM 2

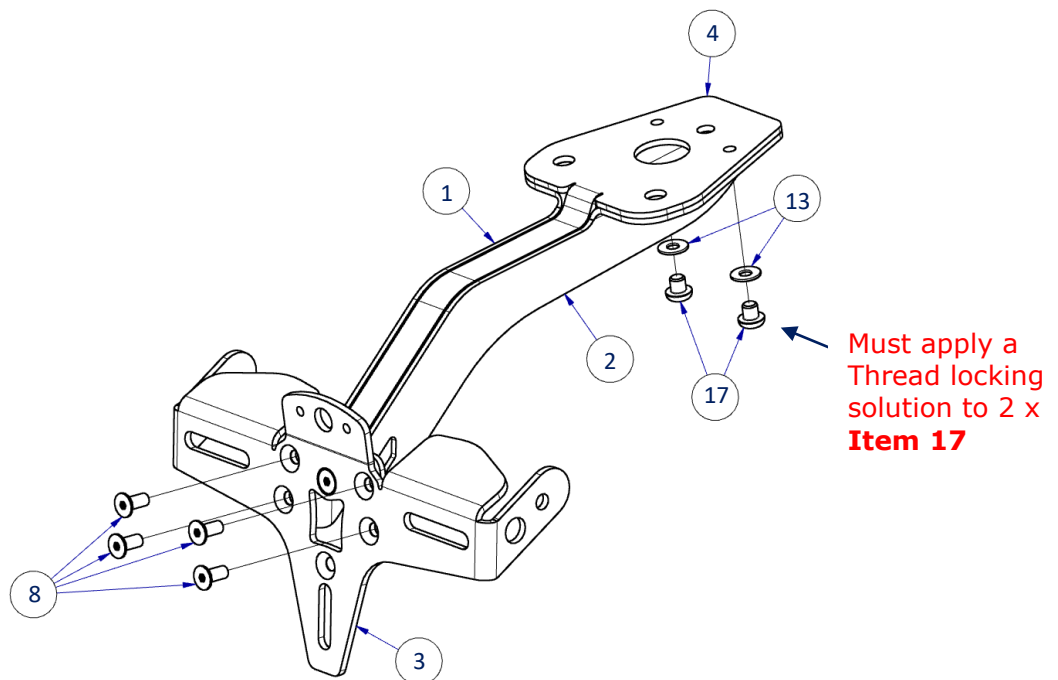

R&G

Unit 1, Shelley's Lane, East Worldham, Alton, Hampshire, GU34 3AQ

Tel: +44 (0)1420 89007 Fax: +44 (0)1420 87301 www.rg-racing.com Email: info@rg-racing.com



ASSEMBLY DIAGRAM 3

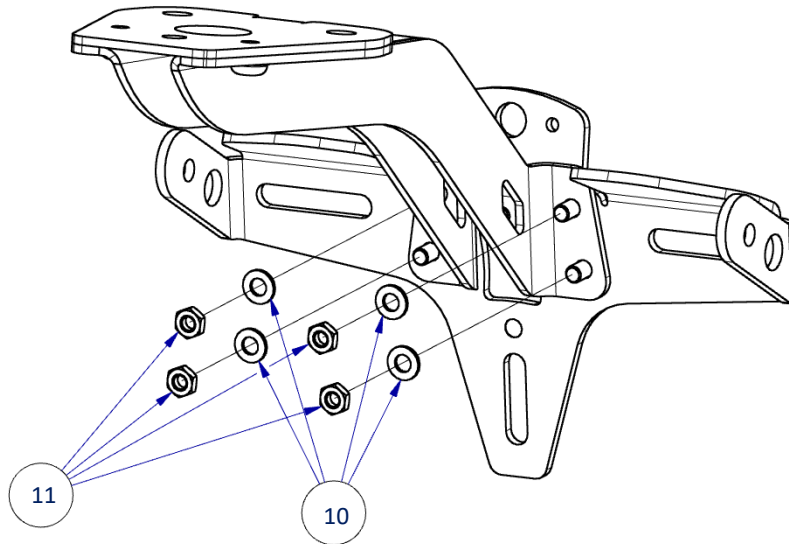

ASSEMBLY DIAGRAM 4

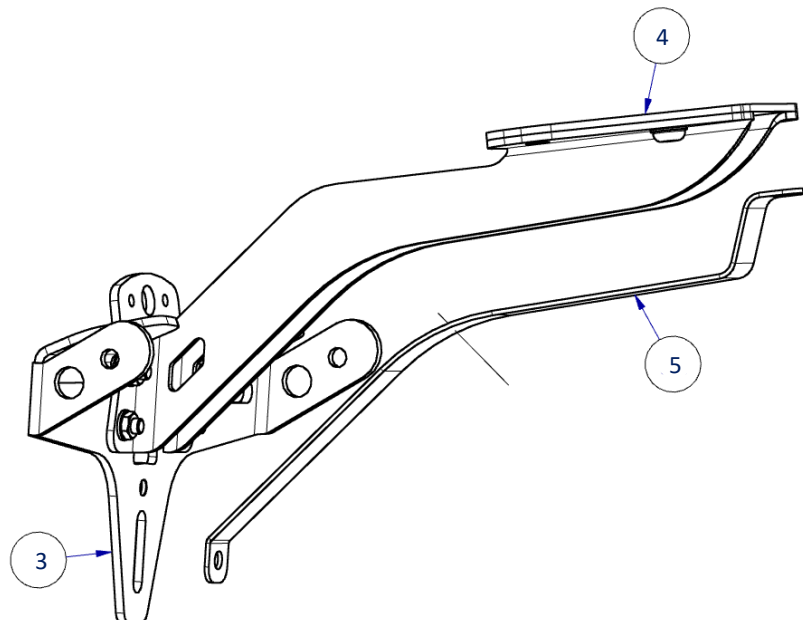



ASSEMBLY DIAGRAM 5

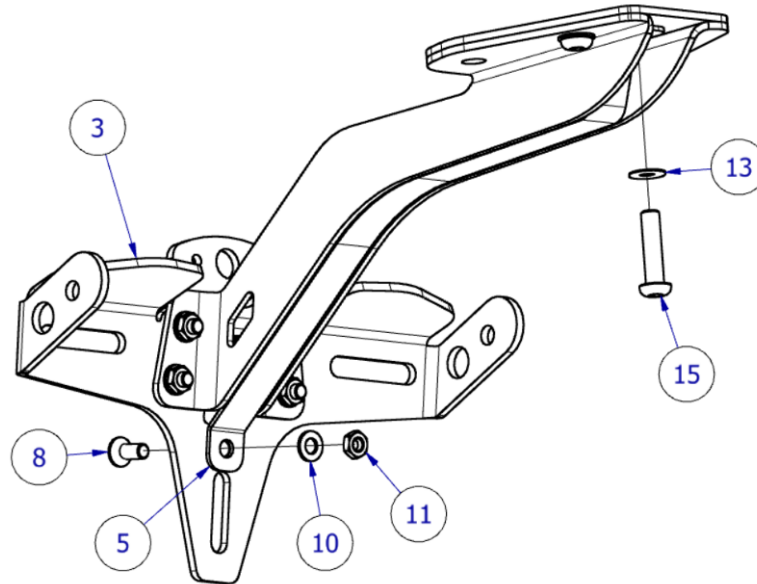

ASSEMBLY DIAGRAM 6

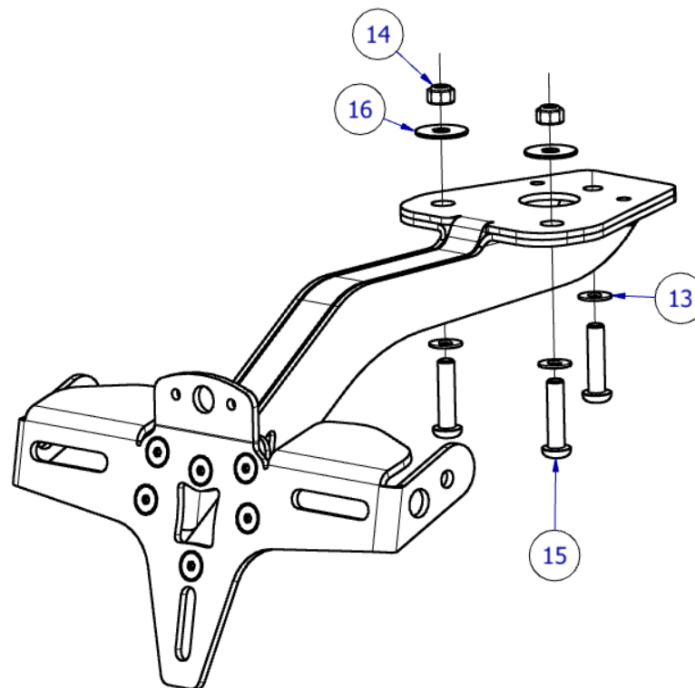

R&G

Unit 1, Shelley's Lane, East Worldham, Alton, Hampshire, GU34 3AQ

Tel: +44 (0)1420 89007 Fax: +44 (0)1420 87301 www.rg-racing.com Email: info@rg-racing.com



FITTING PICTURES



Picture 1

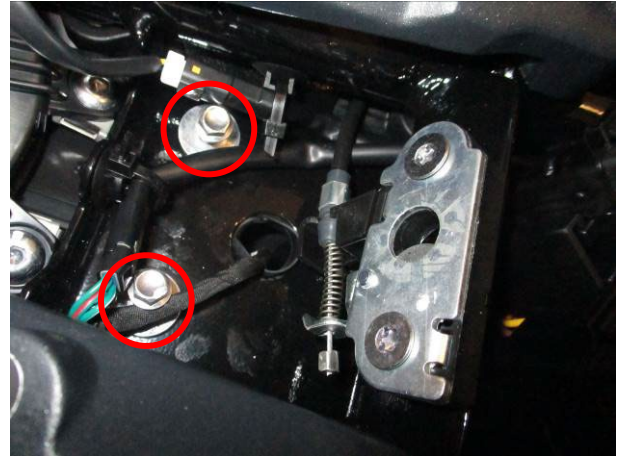

Picture 2



Picture 3

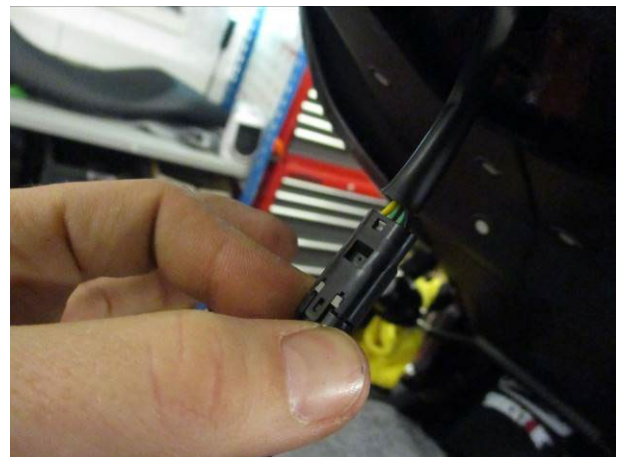

Picture 4



Picture 5

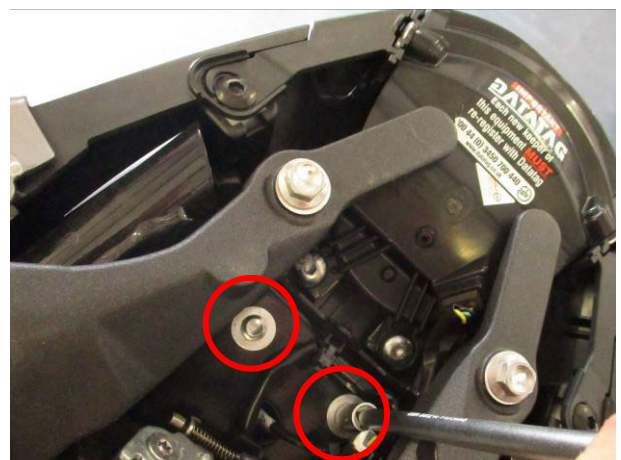

Picture 6

R&G

Unit 1, Shelley's Lane, East Worldham, Alton, Hampshire, GU34 3AQ

Tel: +44 (0)1420 89007 Fax: +44 (0)1420 87301 www.rg-racing.com Email: info@rg-racing.com



FITTING INSTRUCTIONS

Removal of OEM license plate bracket

- Begin by removing the seat using the key slot as shown in **Picture 1**.
- Remove the 2 x bolts shown in **Picture 2** which are location underneath the seat.
- Remove the 1 x bolt shown in **Picture 3**, then carefully lift away the OEM license plate holder.
- Now the OEM license plate holder is loose, it will expose the connector shown in **Picture 4**, disconnect this connector, going careful not to snap the securing tab.
- The OEM license plate holder can now be fully removed.
- Dismantle the OEM license plate holder and remove the OEM indicators ready to install onto the R&G tail tidy as shown in **Picture 5**.

Assembly and Installation of R&G Tail Tidy

- Attach **Item 3** to **Item 4** using the provided fasteners as shown in **Assembly Diagram 1**.
- Secure **Item 1** and **Item 2** as shown in **Assembly Diagram 2** using the provided fasteners also shown in the **Legend**.
- To secure **Item 1** and **Item 2** to the R&G supplied license plate bracket (**Item 3**), please use the washers and Nyloc nuts as shown in **Assembly Diagram 3**.
- Attach the R&G supplied license plate illuminator (**Item 6**) and its shroud to the R&G license plate bracket (**Item 3**), ensuring the wires have been wrapped in heat-shrink (**Item 19**) for protection.
- Secure the OEM indicators to the R&G license plate bracket using the 2 x (M6 x 16mm Cap Head Bolts) (**Item 12**) and 2 x (M6 x 12mm OD washers) (**Item 13**).
- Connect the License plate illuminator and indicators using the provided connector (**Item 7**).
- Tuck the wires up into the R&G tail tidy to your own satisfaction using the provided cable ties (**Item 20**) and self-adhesive clips (**Item 21**).
- Attach the provided cable cover plate (**Item 5**), using the provided fasteners as shown in **Assembly Diagram 4 and 5**.
- With the wires presented through the hole on the main mount face, remove the rubber gasket which is on the OEM license plate holder mount face, and re-fit this on the R&G tail tidy assembly.
- Secure the R&G tail tidy in place using the supplied fasteners as shown in **Assembly Diagram 6 and Picture 6**.
- Test your indicators are illuminating before riding.

Ensure that the wiring does not foul or become trapped during operation.

IMPORTANT: IF FITTING A FULL-SIZE LICENCE PLATE AND PLACING IT FAR DOWN ON THE LICENCE PLATE HANGER, THERE IS A SMALL CHANCE OF THE LICENCE PLATE HITTING THE BACK WHEEL UNDER HEAVY LOAD AND OVER LARGE BUMPS IN THE ROAD. IT IS YOUR RESPONSIBILITY TO CHECK FOR THIS POSSIBILITY AND TAKE AVOIDING ACTION. FAILURE TO CHECK THIS COULD RESULT IN SERIOUS INJURY.

R&G

Unit 1, Shelley's Lane, East Worldham, Alton, Hampshire, GU34 3AQ

Tel: +44 (0)1420 89007 Fax: +44 (0)1420 87301 www.rg-racing.com Email: info@rg-racing.com



ISSUE 1 - 04/08/2021 - (AO)

CONSUMER NOTICE

The catalogue description and any exhibition of samples are only broad indications of the Products and R&G may make design changes which do not diminish their performance or visual appeal and supplying them in such state shall conform to the order. The Buyer acknowledges no representation or warranty (other than as to title) has been given or will apply to the Products other than those in R&G's order or confirmation and the Buyer confirms it has chosen the Products as being of merchantable quality and suitable for its particular purposes. Where R&G fits the Products or undertakes other services it shall exercise reasonable skill and care and rectify any fault free of charge unless the workmanship has been disturbed. The Buyer is responsible for ensuring that the warranty on the motorcycle is not affected by the fitting of the Products. On return of any defective Products R&G shall at its option either supply a replacement or refund the purchase money but shall not be liable if the Products have been modified or used or maintained otherwise than in accordance with R&G's or manufacturer's instructions and good engineering practice or if the defect arises from accident or neglect. Other than identified above and subject to R&G not limiting its liability for causing death and personal injury, it shall not be liable for indirect or consequential loss and otherwise its liability shall be limited to the amounts paid by the Buyer for the Products or the fitting or service concerned. These terms do not affect the Buyer's statutory rights.

R&G RACING RETURNS POLICY (NON-FAULTY GOODS)

Returns must be pre-authorized (if not pre-authorized the return will be rejected). Goods may only be returned direct to us if they were purchased direct from us (customer must prove if necessary). Otherwise to be returned to original vendor. Goods must be in re-sellable condition, in the opinion of R&G Racing. All returns are subject to a 25% restocking and handling fee (25% of the gross value exc. P&P – at the prevailing price at time of purchase). The customer must pay any and all carriage charges. No returns of discontinued products, unless within 14 days of purchase. This policy does not affect your statutory rights and does not refer to faulty goods.

R&G

Unit 1, Shelley's Lane, East Worldham, Alton, Hampshire, GU34 3AQ

Tel: +44 (0)1420 89007 Fax: +44 (0)1420 87301 www.rg-racing.com Email: info@rg-racing.com



NOTICE DE MONTAGE POUR LP0335BK SUPPORT DE PLAQUE
TRIUMPH TIGER SPORT 660 2022-



CE KIT CONTIENT LES ARTICLES ILLUSTRÉS ET ÉTIQUETÉS SUR LA PAGE.

CERTAINES PARTIES PEUVENT ÊTRE PRÉSENTES UNIQUEMENT POUR LA CLARTÉ DES INSTRUCTIONS.

NE PAS PROCÉDER AU MONTAGE TANT QUE VOUS N'ÊTES PAS SÛR QUE TOUTES LES PIÈCES SOIENT PRÉSENTES.

VEUILLEZ LIRE TOUTES LES INSTRUCTIONS AVANT DE CONTINUER.

EN CAS DE DOUTE LORS DU MONTAGE DE NOS PRODUITS, CONSULTEZ UN DE NOS REVENDEURS OU FAITES APPEL À UN TECHNICIEN QUALIFIÉ.

VEUILLEZ NOTER QUE LA FAÇON DONT LE KIT EST EMBALLÉ NE REPRÉSENTE PAS NECESSAIREMENT LA MANIÈRE DE LE MONTER SUR LA MOTO.

SI DES RONDELLES EN CAOUTCHOUC SONT UTILISÉES POUR MAINTENIR LES COMPOSANTS SUR LES BOULONS, ELLES PEUVENT ÊTRE JETÉES.

NOTICE DISPONIBLE AU TÉLÉCHARGEMENT SUR :
WWW.RG-RACING.COM

R&G

Unit 1, Shelley's Lane, East Worldham, Alton, Hampshire, GU34 3AQ
Tel: +44 (0)1420 89007 Fax: +44 (0)1420 87301 www.rg-racing.com Email: info@rg-racing.com



<u>OUTILS REQUIS</u>	<u>VALEURS DE SERRAGE</u>
<ul style="list-style-type: none"> • Clés Allen. • Clé à cliquet + douilles. • Petit tournevis plat. • Un peu de super glue. • Frein filet 	M4 BOULON = 8Nm M5 BOULON = 12Nm M6 BOULON = 15Nm M8 BOULON = 20Nm M10 BOULON = 40Nm M12 BOULON = 40Nm

LÉGENDE

ARTICLE No.	DESCRIPTION	QTÉ
ARTICLE 1	TB0335 PARTIE 1 (SUPPORT EN ACIER GAUCHE PRINCIPAL)	1
ARTICLE 2	TB0335 PARTIE 2 (SUPPORT EN ACIER DROIT PRINCIPAL)	1
ARTICLE 3	TB0335 PARTIE 3 (SUPPORT DE PLAQUE)	1
ARTICLE 4	TB0335 PARTIE 4 (PLAQUE DE MONTAGE EN ACIER AVEC COUVERCLE)	1
ARTICLE 5	TB0335 PARTIE 5 (PLAQUE DE COUVERTURE DE CÂBLAGE)	1
ARTICLE 6	LA0002 (FEU DE PLAQUE)	1
ARTICLE 7	CON0014	1
ARTICLE 8	M5 x 0.80 x 15mm CSK BOULON	5
ARTICLE 9	M5 x 0.80 x 8mm CSK BOULON	1
ARTICLE 10	M5 x 10mm OD RONDELLE	5
ARTICLE 11	M5 x 0.80 ÉCROU	5
ARTICLE 12	M6 x 1.00 16mm BOULON	2
ARTICLE 13	M6 x 12mm RONDELLE	7
ARTICLE 14	M6 x 1.00 ÉCROU	4
ARTICLE 15	M6 x 1.00 x 25mm BOULON	3
ARTICLE 16	M6 x 19mm RONDELLE	2
ARTICLE 17	M6 x 1.00 x 6mm BOULON	2
ARTICLE 18	IWC0002 (CACHE FIL CLIGNOTANT)	2
ARTICLE 19	666-896 (200mm MANCHON THERMO RÉTRACTABLE)	3
ARTICLE 20	CT75 (2.5mm WIDE x 75mm COLLIERS DE SERRAGE)	2
ARTICLE 21	CLIP1 (CLIPS CÂBLE AUTOCOLLANTS)	3

R&G

Unit 1, Shelley's Lane, East Worldham, Alton, Hampshire, GU34 3AQ

Tel: +44 (0)1420 89007 Fax: +44 (0)1420 87301 www.rg-racing.com Email: info@rg-racing.com



ARTICLE 22	REFL3 (RÉFLECTEUR)	1
------------	--------------------	---

SCHÉMA D'ENSEMBLE 1



SCHÉMA D'ENSEMBLE 2



R&G

Unit 1, Shelley's Lane, East Worldham, Alton, Hampshire, GU34 3AQ

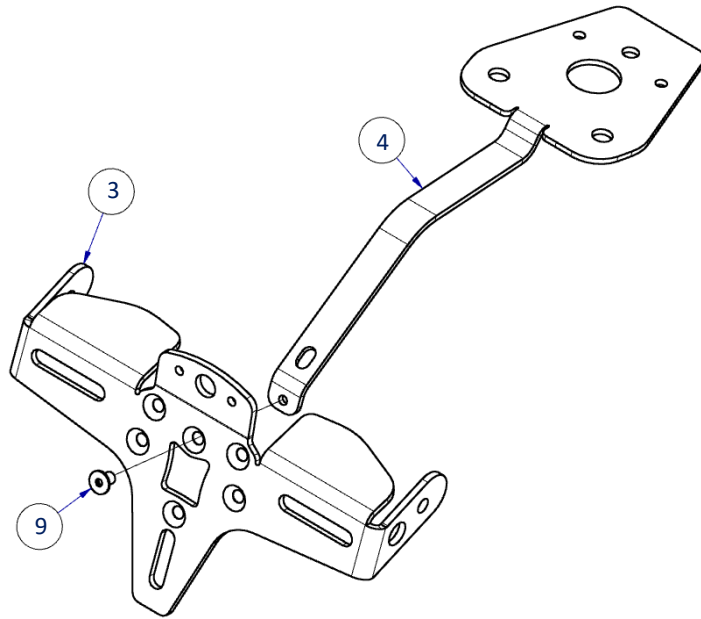
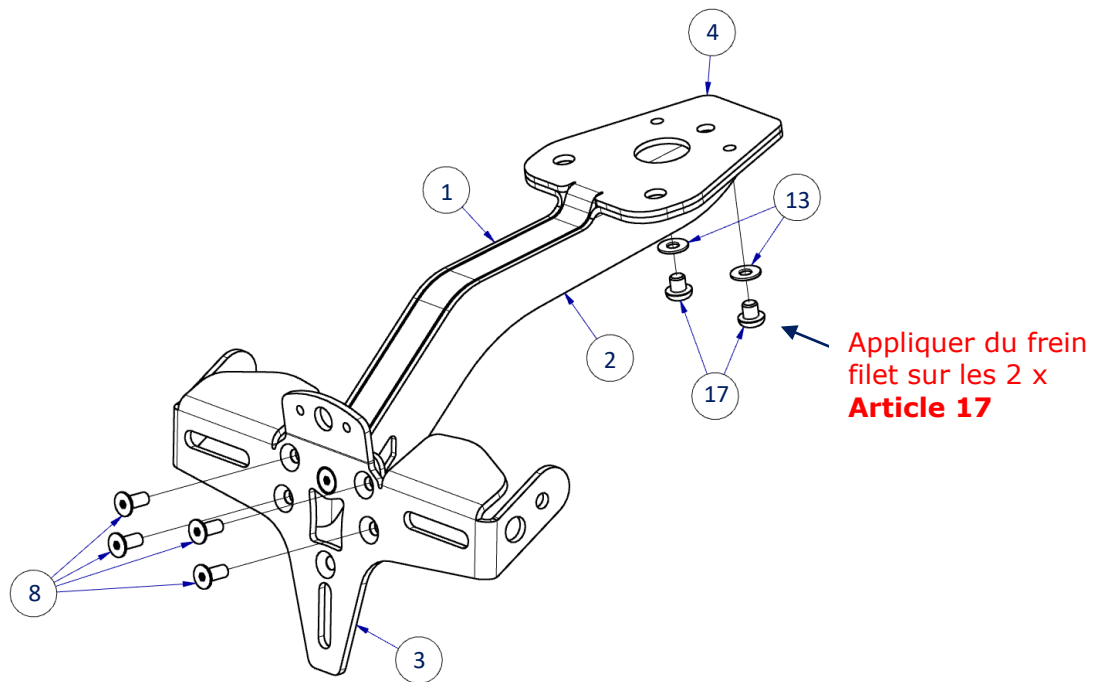
Tel: +44 (0)1420 89007 Fax: +44 (0)1420 87301 www.rg-racing.com Email: info@rg-racing.com





SCHÉMA D'ENSEMBLE 3



SCHÉMA D'ENSEMBLE 4





SCHÉMA D'ENSEMBLE 5

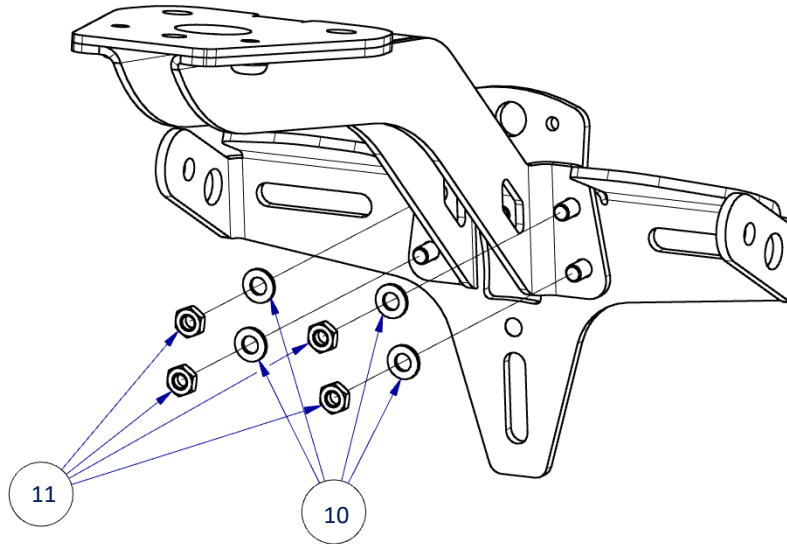

SCHÉMA D'ENSEMBLE 6

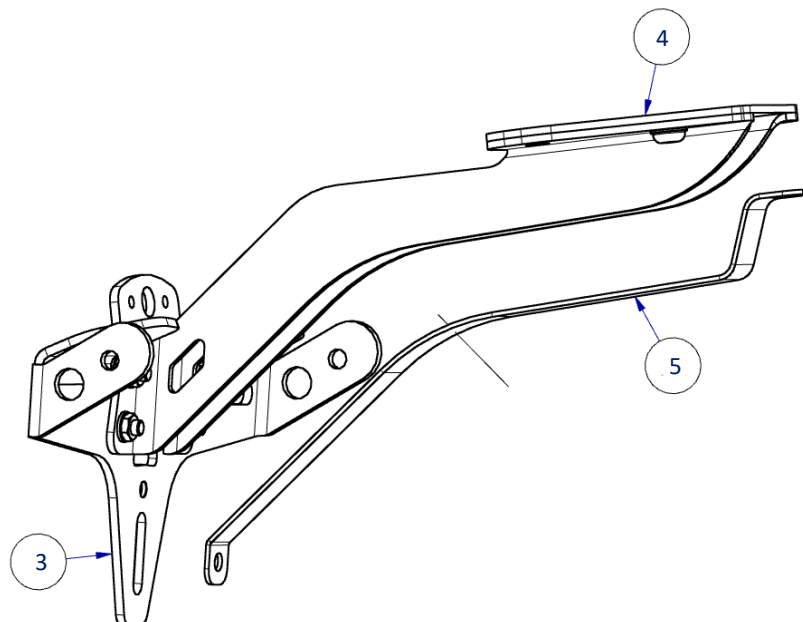

R&G

Unit 1, Shelley's Lane, East Worldham, Alton, Hampshire, GU34 3AQ

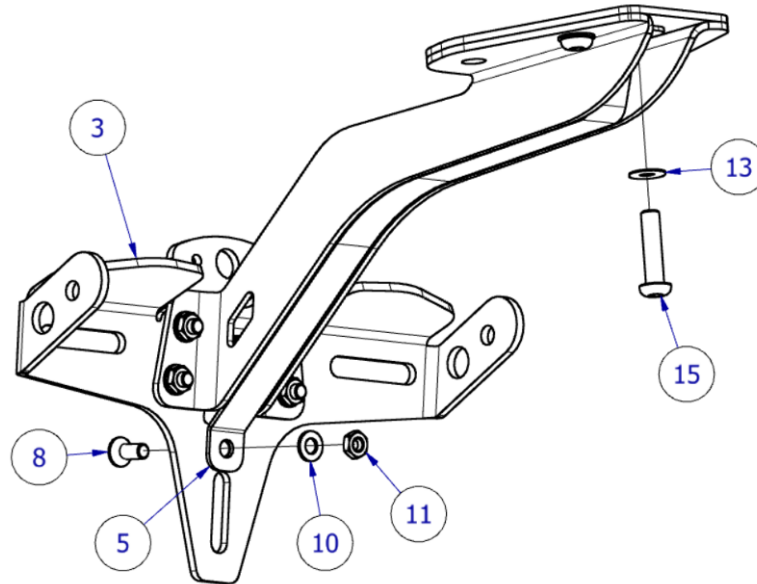
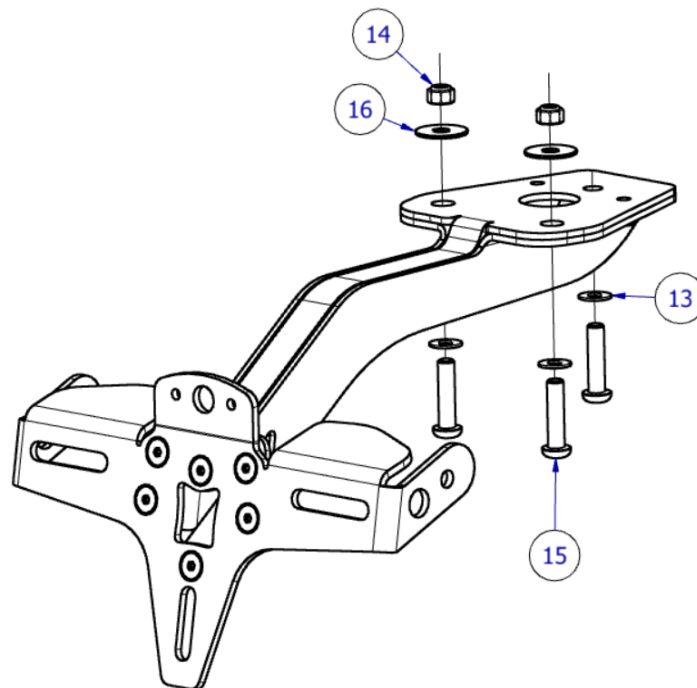
Tel: +44 (0)1420 89007 Fax: +44 (0)1420 87301 www.rg-racing.com Email: info@rg-racing.com



PHOTOS DE MONTAGE



Photo 1

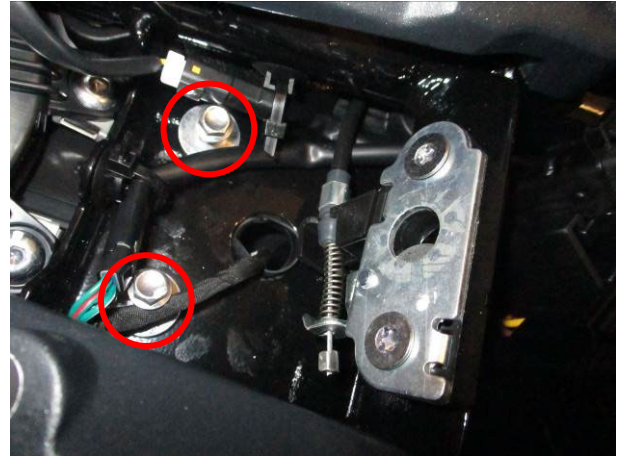

Photo 2



Photo 3

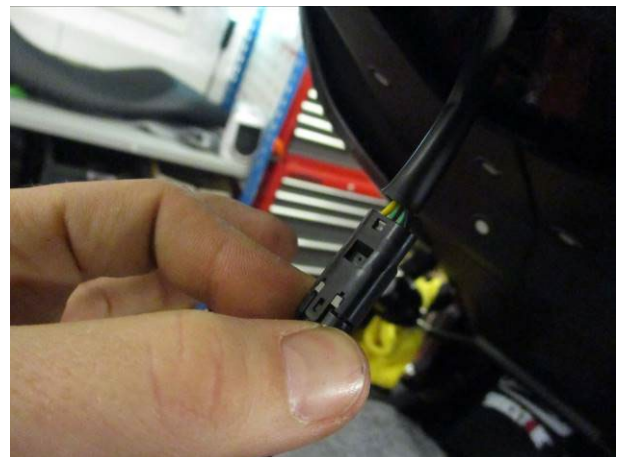

Photo 4



Photo 5

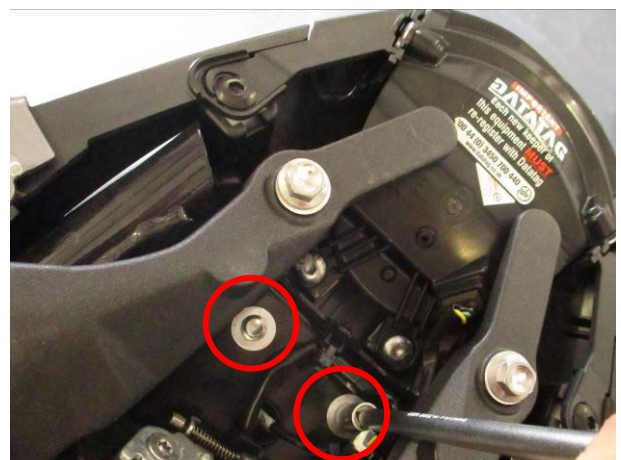

Photo 6

R&G

Unit 1, Shelley's Lane, East Worldham, Alton, Hampshire, GU34 3AQ

Tel: +44 (0)1420 89007 Fax: +44 (0)1420 87301 www.rg-racing.com Email: info@rg-racing.com



NOTICE DE MONTAGE

Enlever le support de plaque d'origine

- Commencez par retirer le siège à l'aide de la fente de clé comme indiqué sur la photo 1.
- Retirez les 2 x boulons illustrés sur la photo 2 qui se trouvent sous le siège.
- Retirez le 1 x boulon illustré sur la photo 3, puis soulevez délicatement le support de plaque d'immatriculation d'origine.
- Maintenant que le support de plaque d'immatriculation d'origine est desserré, il exposera le connecteur illustré sur la photo 4, débranchez ce connecteur en faisant attention de ne pas casser la languette de fixation.
- Le support de plaque d'immatriculation d'origine peut maintenant être entièrement retiré.
- Démontez le support de plaque d'immatriculation d'origine et retirez les clignotants d'origine prêts à être installés sur le support arrière R&G comme indiqué sur la photo 5.

Assemblage et installation du support de plaque R&G

- Attach **Article 3** to **Article 4** using the provided fasteners as shown in **Assembly Diagram 1**.
- Secure **Article 1** and **Article 2** as shown in **Assembly Diagram 2** using the provided fasteners also shown in the **Legend**.
- To secure **Article 1** and **Article 2** to the R&G supplied license plate bracket (**Article 3**), please use the washers and Nyloc nuts as shown in **Assembly Diagram 3**.
- Attach the R&G supplied license plate illuminator (**Article 6**) and its shroud to the R&G license plate bracket (**Article 3**), ensuring the wires have been wrapped in heat-shrink (**Article 19**) for protection.
- Secure the OEM indicators to the R&G license plate bracket using the 2 x (M6 x 16mm Cap Head Bolts) (**Article 12**) and 2 x (M6 x 12mm OD washers) (**Article 13**).
- Connect the License plate illuminator and indicators using the provided connector (**Article 7**).
- Tuck the wires up into the R&G tail tidy to your own satisfaction using the provided cable ties (**Article 20**) and self-adhesive clips (**Article 21**).
- Attach the provided cable cover plate (**Article 5**), using the provided fasteners as shown in **Assembly Diagram 4 and 5**.
- With the wires presented through the hole on the main mount face, remove the rubber gasket which is on the OEM license plate holder mount face, and re-fit this on the R&G tail tidy assembly.
- Secure the R&G tail tidy in place using the supplied fasteners as shown in **Assembly Diagram 6 and Photo 6**.
- Test your indicators are illuminating before riding.
- Fixez l'article 3 à l'article 4 à l'aide des attaches fournies comme indiqué dans le schéma d'assemblage 1.
- Fixez l'article 1 et l'article 2 comme indiqué sur le schéma d'assemblage 2 à l'aide des fixations fournies également indiquées dans la légende.
- Pour fixer l'article 1 et l'article 2 au support de plaque d'immatriculation fourni par R&G (article 3), veuillez utiliser les rondelles et les écrous comme indiqué sur le schéma de montage 3.

R&G

Unit 1, Shelley's Lane, East Worldham, Alton, Hampshire, GU34 3AQ

Tel: +44 (0)1420 89007 Fax: +44 (0)1420 87301 www.rg-racing.com Email: info@rg-racing.com



- Fixez le feu de plaque d'immatriculation fourni par R&G (article 6) et son enveloppe sur le support de plaque d'immatriculation R&G (article 3), en vous assurant que les fils ont été enveloppés dans une gaine thermo rétractable (article 19) pour les protéger.
- Fixez les clignotants d'origine sur le support de plaque d'immatriculation R&G à l'aide des 2 x (M6 x 16 mm boulons) (Article 12) et 2 x (M6 x 12 mm OD rondelles) (Article 13).
- Connectez l'éclairage de plaque et les clignotants à l'aide du connecteur fourni (Article 7).
- Rentrez les fils dans le support arrière R&G en utilisant les colliers de serrage fournis (article 20) et les clips autocollants (article 21).
- Fixez la plaque de couverture de câble fournie (article 5), en utilisant les attaches fournies comme indiqué sur les schémas d'assemblage 4 et 5.
- Une fois les fils présentés à travers le trou sur la face de montage principale, retirez le joint en caoutchouc qui se trouve sur la face de montage du support de plaque d'immatriculation d'origine et remettez-le en place sur l'ensemble du support arrière R&G.
- Fixez le support arrière R&G en place à l'aide des attaches fournies comme indiqué sur le schéma d'assemblage 6 et la photo 6.
- Testez les clignotants avant de rouler.

Assurez-vous que le câblage ne s'encrasse pas ou ne se coince pas pendant le fonctionnement.

IMPORTANT : SI VOUS MONTEZ UNE PLAQUE D'IMMATRICULATION LARGE ET QUE VOUS LA PLACEZ ASSEZ BASSE SUR LE SUPPORT DE PLAQUE D'IMMATRICULATION, IL EST POSSIBLE QUE LA PLAQUE D'IMMATRICULATION TOUCHE LA ROUE ARRIÈRE SOUS UNE CHARGE LOURDE ET SUR DE GROSSES BOSSES SUR LA ROUTE. IL EST DE VOTRE RESPONSABILITÉ DE VÉRIFIER CETTE POSSIBILITÉ ET DE PRENDRE DES MESURES POUR ÉVITER. NE PAS VÉRIFIER CELA POURRAIT ENTRAÎNER DES BLESSURES GRAVES.

ISSUE 1 - 04/08/2021 - (AO)

CONSUMER NOTICE

The catalogue description and any exhibition of samples are only broad indications of the Products and R&G may make design changes which do not diminish their performance or visual appeal and supplying them in such state shall conform to the order. The Buyer acknowledges no representation or warranty (other than as to title) has been given or will apply to the Products other than those in R&G's order or confirmation and the Buyer confirms it has chosen the Products as being of merchantable quality and suitable for its particular purposes. Where R&G fits the Products or undertakes other services it shall exercise reasonable skill and care and rectify any fault free of charge unless the workmanship has been disturbed. The Buyer is responsible for ensuring that the warranty on the motorcycle is not affected by the fitting of the Products. On return of any defective Products R&G shall at its option either supply a replacement or refund the purchase money but shall not be liable if the Products have been modified or used or maintained otherwise than in accordance with R&G's or manufacturer's instructions and good engineering practice or if the defect arises from accident or neglect. Other than identified above and subject to R&G not limiting its liability for causing death and personal injury, it shall not be liable for indirect or consequential loss and otherwise its liability shall be limited to the amounts paid by the Buyer for the Products or the fitting or service concerned. These terms do not affect the Buyer's statutory rights.

R&G RACING RETURNS POLICY (NON-FAULTY GOODS)

Returns must be pre-authorized (if not pre-authorized the return will be rejected). Goods may only be returned direct to us if they were purchased direct from us (customer must prove if necessary). Otherwise to be returned to original vendor. Goods must be in re-sellable condition, in the opinion of R&G Racing. All returns are subject to a 25% restocking and handling fee (25% of the gross value exc. P&P - at the prevailing price at time of purchase). The customer must pay any and all carriage charges. No returns of discontinued products, unless within 14 days of purchase. This policy does not affect your statutory rights and does not refer to faulty goods.

R&G

Unit 1, Shelley's Lane, East Worldham, Alton, Hampshire, GU34 3AQ

Tel: +44 (0)1420 89007 Fax: +44 (0)1420 87301 www.rg-racing.com Email: info@rg-racing.com



**MONTAGEANLEITUNG FÜR LP0335BK KENNZEICHENHALTER
TRIUMPH TIGER SPORT 660 2022-**



Alle Kit-Teile sind auf den nachfolgenden Seiten abgebildet und gekennzeichnet.

Die abgebildeten Teile dienen lediglich zur Erklärung.

Überprüfen Sie zuerst, dass alle Teile vorhanden sind.

Lesen Sie die Montageanleitung komplett durch, bevor Sie anfangen.

**WENN SIE BEI DER MONTAGE DIESES PRODUKTES UNSICHER SIND, BITTE EINEN
UNSERER HÄNDLER KONTAKTIEREN ODER DAS KIT VON EINEM QUALIFIZIERTEN
ZWEIRAD-MECHANIKER MONTIEREN LASSEN.**

Die Verpackung der Teile stellt nicht die Reihenfolge der Montage dar.

Hinweis für Kits mit Plastikunterlegscheiben an den Schrauben –
Diese Plastik-Unterlegscheiben werden nicht für den Einbau benötigt

**EINE DIGITALE VERSION DIESER MONTAGEANLEITUNG KANN AUF
FOLGENDER SEITE HERUNTERGELADEN WERDEN:**

WWW.RG-RACING.COM

R&G

Unit 1, Shelley's Lane, East Worldham, Alton, Hampshire, GU34 3AQ

Tel: +44 (0)1420 89007 Fax: +44 (0)1420 87301 www.rg-racing.com Email: info@rg-racing.com



<u>SIE BENÖTIGEN FOLGENDES WERKZEUG</u>	<u>ALLGEM. ANZUGDREHMOMENT</u>
<ul style="list-style-type: none"> • Satz Inbusschlüssel • Satz Steckschlüssel • Kl. Flachklingen-Schraubenzieher • Kl. Menge Sekundenkleber • Threadlocker/Schraubensicherung 	M4 SCHRAUBE = 8Nm M5 SCHRAUBE = 12Nm M6 SCHRAUBE = 15Nm M8 SCHRAUBE = 20Nm M10 SCHRAUBE = 40Nm M12 SCHRAUBE = 40Nm

LIEFERUMFANG

ARTIKEL NR.	BESCHREIBUNG	MENGE
ARTIKEL 1	TB0335 TEIL 1 (HAUPHALTERUNG AUS STAHL LINKE SEITE)	1
ARTIKEL 2	TB0335 TEIL 2 (HAUPHALTERUNG AUS STAHL RECHTE SEITE)	1
ARTIKEL 3	TB0335 TEIL 3 (KENNZEICHENHALTER AUS ALUMINIUM)	1
ARTIKEL 4	TB0335 TEIL 4 (MONTAGEPLATTE AUS STAHL MIT ABDECKUNG)	1
ARTIKEL 5	TB0335 TEIL 5 (ABDECKUNG - VERKABELUNG)	1
ARTIKEL 6	LA0002 (KENNZEICHENBELEUCHTUNG)	1
ARTIKEL 7	CON0014	1
ARTIKEL 8	M5 x 0.80 x 15mm SENKSCHRAUBE	5
ARTIKEL 9	M5 x 0.80 x 8mm SENKSCHRAUBE	1
ARTIKEL 10	M5 x 10mm UNTERLEGSCHIEBE	5
ARTIKEL 11	M5 x 0.80 SELBSTSICHERNDE MUTTER	5
ARTIKEL 12	M6 x 1.00 16mm INBUSSCHRAUBE	2
ARTIKEL 13	M6 x 12mm UNTERLEGSCHIEBE	7
ARTIKEL 14	M6 x 1.00 SELBSTSICHERNDE MUTTER	4
ARTIKEL 15	M6 x 1.00 x 25mm INBUSSCHRAUBE	3
ARTIKEL 16	M6 x 19mm UNTERLEGSCHIEBE	2
ARTIKEL 17	M6 x 1.00 x 6mm INBUSSCHRAUBE	2
ARTIKEL 18	IWC0002 (BLINKER KABEL-ABDECKUNG)	2
ARTIKEL 19	666-896 (200mm SCHRUMPFSCHLAUCH)	3
ARTIKEL 20	CT75 (2.5mm BREIT x 75mm LANG KABELBINDER)	2
ARTIKEL 21	CLIP1 (SELBSTKLEBENDE KABELCLIPS)	3
ARTIKEL 22	REFL3 (RÜCKSTRAHLER)	1

R&G

Unit 1, Shelley's Lane, East Worldham, Alton, Hampshire, GU34 3AQ

Tel: +44 (0)1420 89007 Fax: +44 (0)1420 87301 www.rg-racing.com Email: info@rg-racing.com



ZUSAMMENBAU ZEICHNUNG 1

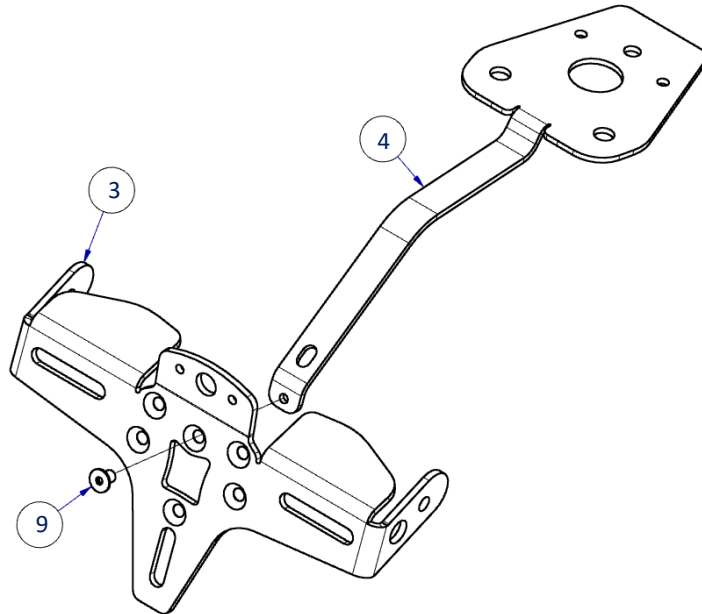

ZUSAMMENBAU ZEICHNUNG 2

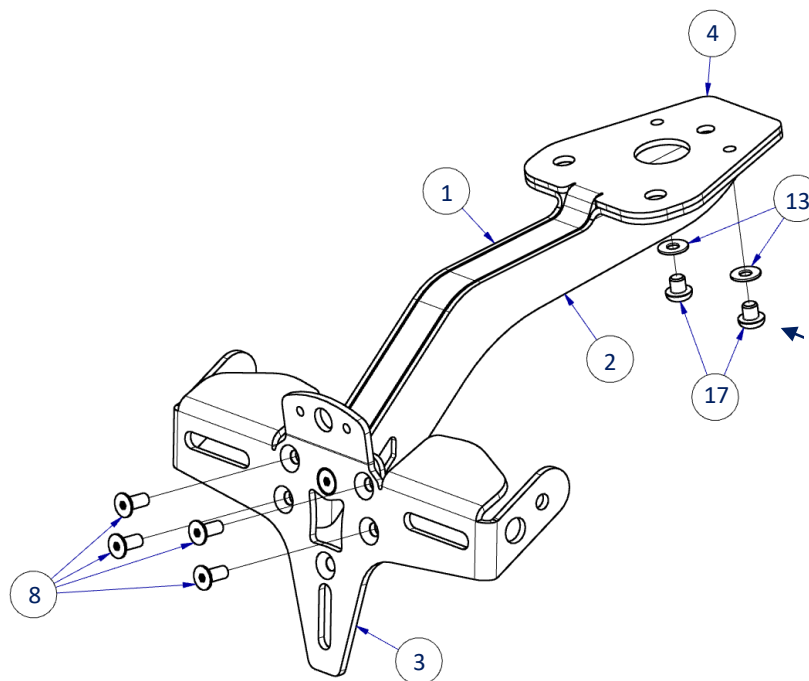

**Unbedingt
Schraubensicherungs-
-Lack an die 2 x
Artikel 17 anbringen**

R&G

Unit 1, Shelley's Lane, East Worldham, Alton, Hampshire, GU34 3AQ

Tel: +44 (0)1420 89007 Fax: +44 (0)1420 87301 www.rg-racing.com Email: info@rg-racing.com



ZUSAMMENBAU ZEICHNUNG 3

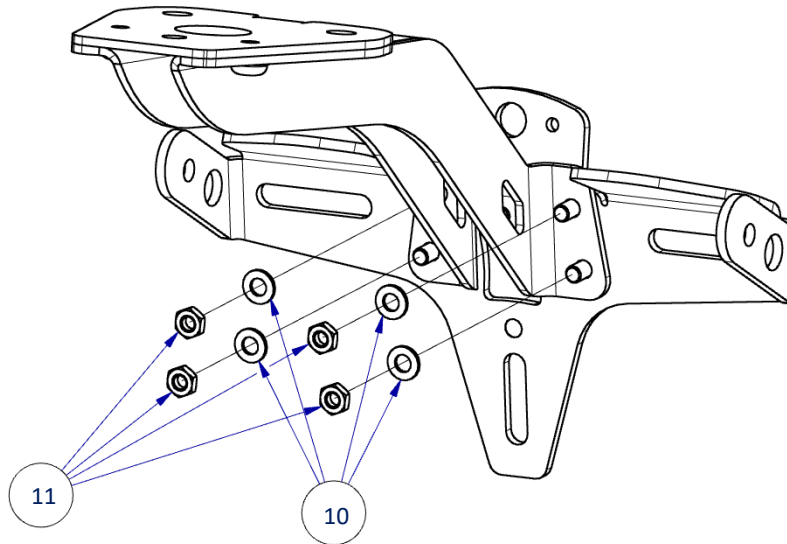

ZUSAMMENBAU ZEICHNUNG 4

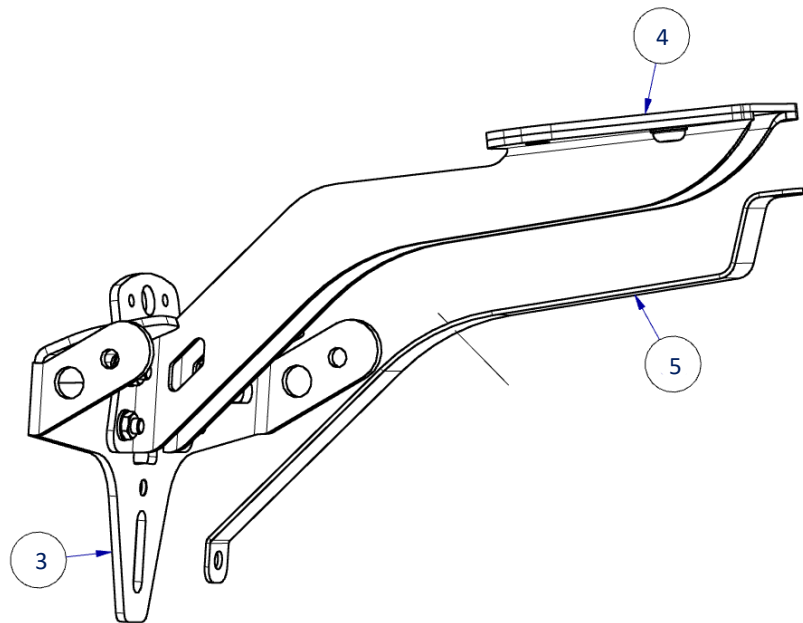



ZUSAMMENBAU ZEICHNUNG 5

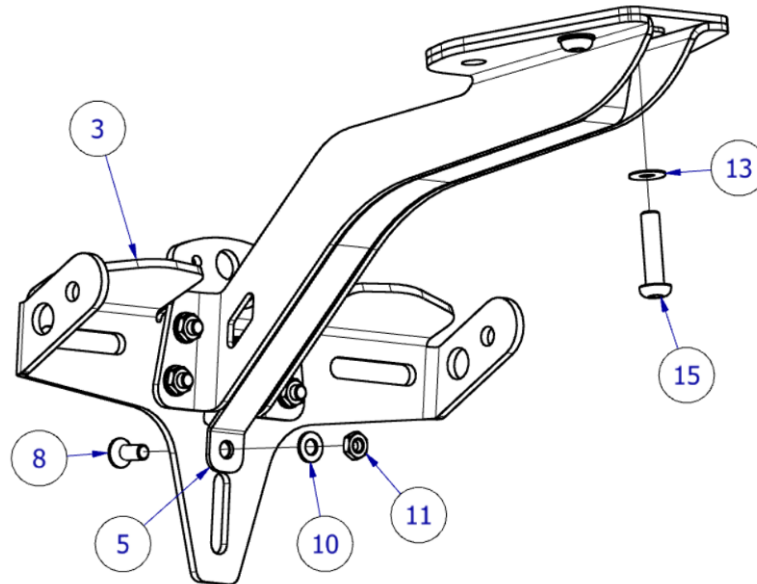

ZUSAMMENBAU ZEICHNUNG 6

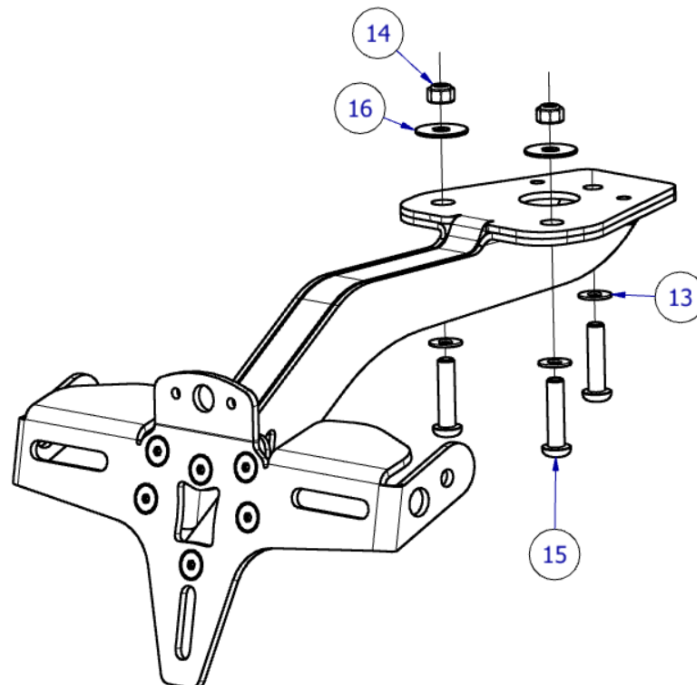

R&G

Unit 1, Shelley's Lane, East Worldham, Alton, Hampshire, GU34 3AQ

Tel: +44 (0)1420 89007 Fax: +44 (0)1420 87301 www.rg-racing.com Email: info@rg-racing.com



MONTAGE ABILDUNGEN



Abbildung 1



Abbildung 2



Abbildung 3

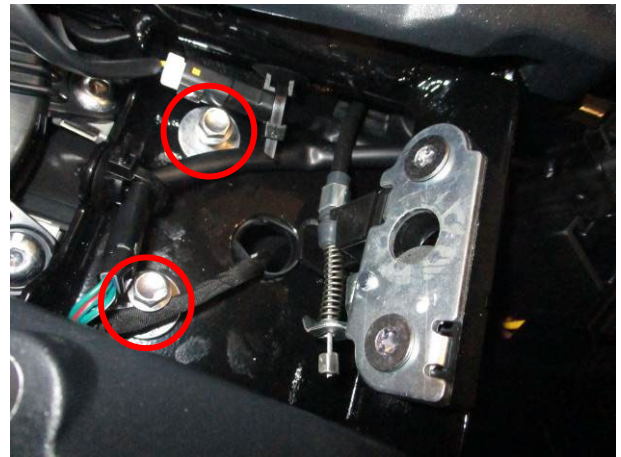

Abbildung 4



Abbildung 5

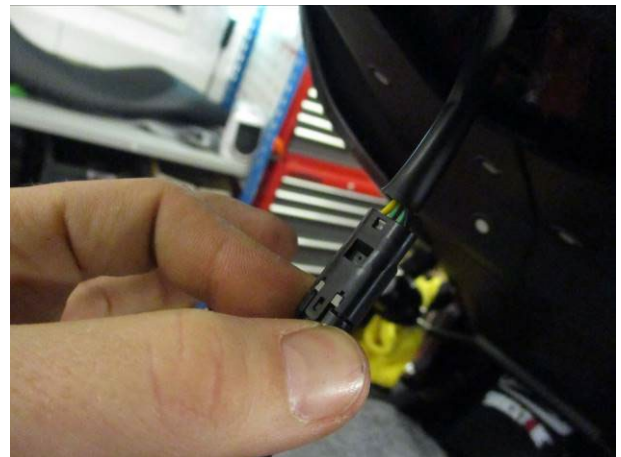

Abbildung 6

R&G

Unit 1, Shelley's Lane, East Worldham, Alton, Hampshire, GU34 3AQ

Tel: +44 (0)1420 89007 Fax: +44 (0)1420 87301 www.rg-racing.com Email: info@rg-racing.com

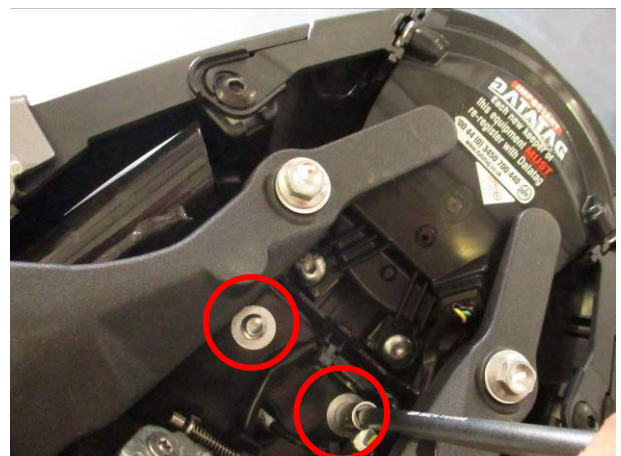

MONTAGEANLEITUNG

Entfernung des Originalkennzeichenhalters

- Entfernen Sie zuerst den Sitz wie in **Abbildung 1** abgebildet.
- Entfernen Sie die 2 x Schrauben unter dem Sitz, die in **Abbildung 2** abgebildet sind.
- Entfernen Sie die Schraube, die in **Abbildung 3** abgebildet ist, dann den Originalkennzeichenhalter abheben.
- Nachdem der Originalkennzeichenhalter lose ist, können Sie den Verbinder sehen, der in **Abbildung 4** abgebildet ist. Trennen Sie diesen Verbinder und achten Sie darauf, dass Sie die Sicherungslasche nicht reißen.
- Der Originalkennzeichenhalter kann nun komplett entfernt werden.
- Den Originalkennzeichenhalter auseinander bauen und die Originalblinker entfernen, um sie am neuen R&G Kennzeichenhalter gleich montieren zu können – siehe **Abbildung 5**.

Zusammenbau und Montage des R&G Kennzeichenhalters

- Benutzen Sie die Befestigungen vom Kit, um **Artikel 3** mit **Artikel 4** miteinander zu verbinden wie in **Zusammenbau Zeichnung 1** abgebildet.
- Befestigen Sie **Artikel 1** und **Artikel 2** wie in **Assembly Zeichnung 2** abgebildet mit den mitgelieferten Befestigungen, diese sind gesondert abgebildet.
- Um **Artikel 1** und **Artikel 2** am R&G Kennzeichenhalter (**Artikel 3**) zu befestigen, die Unterlegscheiben und selbstsichernden Muttern benutzen, die in **Zusammenbau Zeichnung 3** abgebildet sind.
- Die R&G Kennzeichenbeleuchtung vom Kit (**Artikel 6**) und die dazugehörige Abdeckung am Kennzeichenhalter anbringen (**Artikel 3**) – die Kabel zuvor mit Schrumpfschlauch wickeln (**Artikel 19**).
- Sichern Sie die Originalblinker am R&G Kennzeichenhalter mit den 2 x (M6 x 16mm Inbusschrauben) (**Artikel 12**) und 2 x (M6 x 12mm OD Unterlegscheiben) (**Artikel 13**).
- Verbinden Sie die R&G Kennzeichenbeleuchtung und Blinker mit dem mitgelieferten Verbinder (**Artikel 7**).
- Die Kabel im R&G Kennzeichenhalter ordentlich verstauen mit den mitgelieferten Kabelbinder (**Artikel 20**) und selbstklebenden Clips (**Artikel 21**).
- Die Kabel-Abdeckplatte vom Kit (**Artikel 5**) mit den mitgelieferten Befestigungen anbringen und befestigen wie in **den Zeichnungen Zusammenbau Nr. 4 und 5** abgebildet.
- Nachdem die Kabel durch die Öffnung in der Haupthalterung geführt wurden, entfernen Sie die Gummidichtung an der Originalhalterung und montieren Sie sie am R&G Kennzeichenhalter.
- Sichern Sie den R&G Kennzeichenhalter in Position mit den mitgelieferten Befestigungen wie in der **Zeichnung Zusammenbau 6 und Abbildung 6** abgebildet.
- Überprüfen Sie, dass die Blinker ordnungsgemäß leuchten, bevor Sie mit dem Motorrad fahren.

Stellen Sie sicher, dass die Verkabelung nicht während der Fahrt eingeklemmt oder locker werden kann.

WICHTIG: WENN EIN GROSSES KENNZEICHEN ZU WEIT NACH UNTEN MONTIERT WIRD, BESTEHT BEI SCHWERER LAST ODER DURCH GROSSE BODENWELLEN EIN

R&G

Unit 1, Shelley's Lane, East Worldham, Alton, Hampshire, GU34 3AQ

Tel: +44 (0)1420 89007 Fax: +44 (0)1420 87301 www.rg-racing.com Email: info@rg-racing.com



GERINGES RISIKO, DASS DAS KENNZEICHEN AN DAS HINTERRAD STOSSEN KANN. ES LIEGT IN IHRER VERANTWORTUNG DIES ZU ÜBERPRÜFEN UND, WENN NOTWENDIG, VORBEUGENDE MASSNAHMEN ZU ERGREIFEN. DIE NICHTBEACHTUNG DIESES SICHERHEITSHINWEISES KANN ZU SCHWEREN VERLETZUNGEN FÜHREN.

AUSGABE 1 - 04/08/2021 - (AO)

CONSUMER NOTICE

The catalogue description and any exhibition of samples are only broad indications of the Products and R&G may make design changes which do not diminish their performance or visual appeal and supplying them in such state shall conform to the order. The Buyer acknowledges no representation or warranty (other than as to title) has been given or will apply to the Products other than those in R&G's order or confirmation and the Buyer confirms it has chosen the Products as being of merchantable quality and suitable for its particular purposes. Where R&G fits the Products or undertakes other services it shall exercise reasonable skill and care and rectify any fault free of charge unless the workmanship has been disturbed. The Buyer is responsible for ensuring that the warranty on the motorcycle is not affected by the fitting of the Products. On return of any defective Products R&G shall at its option either supply a replacement or refund the purchase money but shall not be liable if the Products have been modified or used or maintained otherwise than in accordance with R&G's or manufacturer's instructions and good engineering practice or if the defect arises from accident or neglect. Other than identified above and subject to R&G not limiting its liability for causing death and personal injury, it shall not be liable for indirect or consequential loss and otherwise its liability shall be limited to the amounts paid by the Buyer for the Products or the fitting or service concerned. These terms do not affect the Buyer's statutory rights.

R&G RACING RETURNS POLICY (NON-FAULTY GOODS)

Returns must be pre-authorized (if not pre-authorized the return will be rejected). Goods may only be returned direct to us if they were purchased direct from us (customer must prove if necessary). Otherwise to be returned to original vendor. Goods must be in re-sellable condition, in the opinion of R&G Racing. All returns are subject to a 25% restocking and handling fee (25% of the gross value exc. P&P - at the prevailing price at time of purchase). The customer must pay any and all carriage charges. No returns of discontinued products, unless within 14 days of purchase. This policy does not affect your statutory rights and does not refer to faulty goods.

R&G

Unit 1, Shelley's Lane, East Worldham, Alton, Hampshire, GU34 3AQ

Tel: +44 (0)1420 89007 Fax: +44 (0)1420 87301 www.rg-racing.com Email: info@rg-racing.com